

# FUKUDA

POWER BACK UP SYSTEM



# DC UPS



TEGAS KOMBINASI TEKNOLOGI SDN. BHD. (473781-D)

 No. 10 & 12, Jalan Tamborin 33/23, Seksyen 33,  
40400 Shah Alam, Selangor.

 Tel:  
03-51224160 / 03-51224161

 Fax:  
03-51225844

 E-mail:  
tktsb@fukuda.com.my



# FUKUDA

## POWER BACK UP SYSTEM

## INTRODUCTION

In **1996**, Petronas has launched Malaysia's Cost Reduction Alliance (CORAL) Initiative with the objective of reducing development costs, production costs and project lead time by 30% from 1995 cost base, by year 2000, without compromising quality, health, safety or the environment.

Hence, in **December 1998**, Tegas Kombinasi Teknologi Sdn Bhd, was incorporated to meet the challenge set by CORAL Initiative by becoming the first local company to manufacture and supply the power back-up system for the Oil and Gas industry.

In **March 2000**, Petronas recognized Tegas Kombinasi Teknologi Sdn Bhd's effort. It has been granted the license as a manufacturer of power back-up system under the registered trademark of **FUKUDA**.

**FUKUDA** is derived from a combination of two words:-

- **"FU"** is from Chinese word means "rich in resources", and
- **"KUDA"** is from a Malay word "Kuasa Kuda" or "Horse-Power" which is related to electrical discipline.

Therefore **FUKUDA** means **"Rich in Power"**



## DC UPS

FUKUDA DC UPS systems are engineered to deliver reliable and continuous DC power for critical industrial applications. Built with robust components and advanced technology, our systems ensure uninterrupted performance in the most demanding environments.

# FUKUDA RECTIFIER

## THE PREFERRED CHOICE

FUKUDA range of rectifier has been developed to meet the most severe industrial standards. Primarily in the oil and gas, chemical and petrochemical industries, power generation and distribution, telecommunication and other domains where the highest availability of stable DC power source is required.

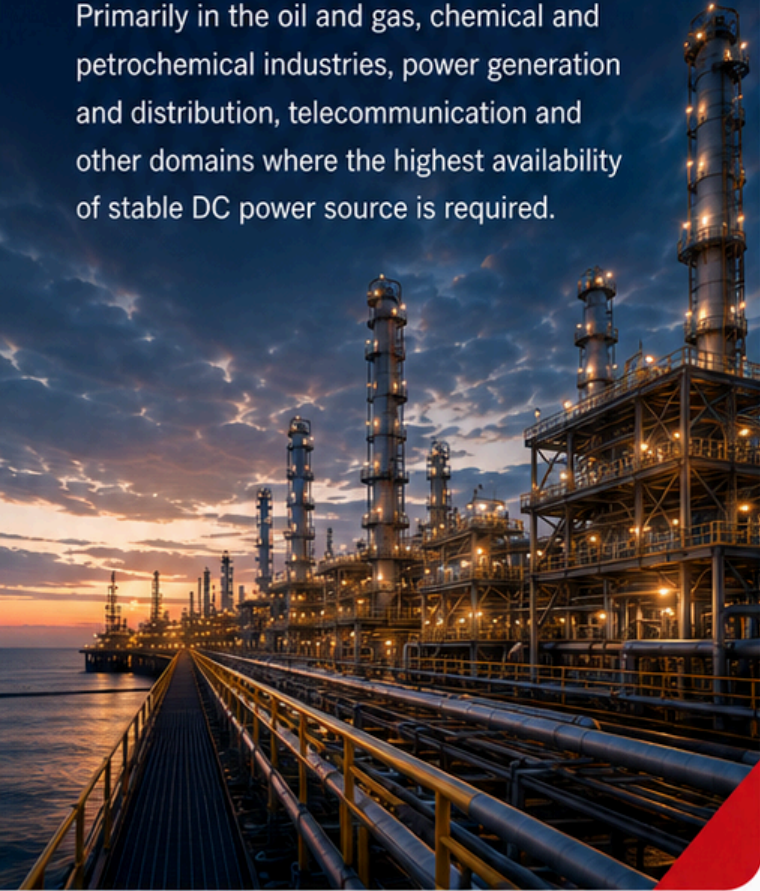

### EXTENSIVE RANGE

FUKUDA offers a wide range to choose from. Single-phase rectifiers use a two-pulse controlled thyristor bridge, while three-phase units employ a six-pulse fully controlled bridge. A twelve-pulse bridge configuration for reduced mains harmonic current is also available. Output voltage ranges from 6 VDC to 250 VDC, and output current ranges from 3 ADC to 1600 ADC. Cabinets are available in either floor-standing or wall-mounted designs. Special cabinet sizes, protection ratings, and colors can also be customized to suit your system requirements.



### MINIMUM MAINTENANCE

The rectifier requires only occasional maintenance and checks, with no special tools needed. In addition to its ease of operation, FUKUDA rectifiers are designed for optimal serviceability. A well-planned layout ensures all components are front-accessible. In the unlikely event of a fault, the alarm display clearly indicates the issue location, enabling quick troubleshooting and repair. Replacement of printed circuit boards is made easy with pull-out connectors.



### EASE OF OPERATION

FUKUDA rectifiers are adaptable to a wide range of applications. The FD-1 and FD-3 series are ideally suited for equipment that uses delicate electronics, designed to meet the sophisticated and time-critical demands of various environments.



### VERSATILITY

The rectifier is designed to be user-friendly. Once commissioned, the unit automatically maintains the battery in a fully charged state. Even after a power interruption, the rectifier will restore the battery to its full capacity automatically, without any human intervention.



### HIGH QUALITY

This power electronic equipment is designed and built in accordance with IEC/EN standards. Carefully selected components, in line with international guidelines, result in highly reliable equipment. Rigorous testing in accordance with IEC 146 ensures that the finished products are delivered with the highest quality.



### APPLICATION STANDARDS

FUKUDA power electronic equipment is designed and built in accordance with the applicable sections of IEC standards or other standards/specifications as approved by the client.

**ENGINEERED FOR  
CRITICAL POWER.  
BUILT FOR  
RELIABILITY.**



OIL & GAS



CHEMICAL &  
PETROCHEMICAL



POWER  
GENERATION



POWER  
DISTRIBUTION



TELECOMMUNICATION



AND OTHER  
INDUSTRIES



**STABLE DC POWER.  
STRONGER OPERATIONS.**



RELIABLE  
PERFORMANCE



MAXIMUM  
AVAILABILITY



CONTINUOUS  
PROTECTION

# TECHNICAL FEATURES

## STANDARD PRODUCT



**ENGINEERED FOR  
CRITICAL POWER.  
BUILT FOR  
RELIABILITY.**



**RELIABLE  
PERFORMANCE**



**RUGGED  
DESIGN**



**EASY TO  
OPERATE**



**MAXIMUM  
AVAILABILITY**

### CABINET DIMENSIONS

MODEL	HEIGHT (mm)	WIDTH (mm)	DEPTH (mm)
DA14	460	400	270
DA18	610	430	330
DA21	790	500	380
DB36	1230	670	490
DB47	1630	670	490
DB62	1900	840	800
DB62D	1900	1640	800

Dimensions in millimeters



#### INPUT VOLTAGE

380V or 415V 3 Ph +/- 10%



#### INPUT FREQUENCY

50 OR 60 Hz +/- 6%



#### MAINS FUSE

Recommended  
(see technical data)



#### OUTPUT VOLTAGE

Nominal : 12V, 24V, 48V, 110V  
or 220V DC  
Floating : 80% to approximately  
135% of V nominal  
High Rate : 80% to approximately  
135% of V nominal



#### CHARGE CHARACTERISTICS

Constant current/constant voltage  
(I / V as per IEC 478-1) during float  
charge.



#### OUTPUT STATIC STABILITY (STANDARD)

+/- 1% with DC load and  
simultaneous variations in AC input  
of +/- 10% and frequency variation  
of +/- 6%.



#### OUTPUT CURRENT

5A to 1500A maximum continuous,  
adjustable 20-100% of Inom.



#### CURRENT REGULATION

+/- 2% current limit



#### TEMPERATURE COEFFICIENT

0.03% per °C (of output V)



#### RIPPLE VOLTAGE

**Battery connected:**  
Maximum 1% RMS of nominal DC  
voltage provided battery capacity is  
5 times the charger nominal current  
rating.

**Battery not connected:**  
Maximum 5% RMS of nominal DC  
voltage.



#### LONG TERM STABILITY

0.15% per 1000 hrs (of output V)



#### PROTECTION

Current limitation at 110 % of rated  
current short circuit protected. Slow  
start device AC surge suppressors  
DC output fuse.



#### CONTROL

Rectifier on / off Manual timed  
high-rate / Auto / Float



#### INDICATORS

Rectifier on (Green)  
Float (Green)  
High Rate (Red)



#### DEGREE OF RADIO FREQUENCY INTERFERENCE

G. According to VDE 0875 (optional N.)



#### APPLICABLE STANDARDS

IEC / VDE



#### HIGH VOLTAGE INSULATION

2KV AC for 1 minute between input /  
output and electrical earth.



#### INSULATION RESISTANCE

10 Mohm with 500VDC between  
input / output and electrical earth.



#### AMBIENT TEMPERATURE

**OPERATIONAL**  
-10 to +40 °C  
+40 to +55 °C derate current rating by  
1.25% per °C

**STORAGE**  
-25 to 70 °C

**ATTITUDE**  
To 1000m  
1000m to 4000m derate 6.7% / 1000m

**VENTILATION**  
Natural convection, sufficient clearance  
required above and in front of the  
cubicles at least 500mm.  
Chargers/rectifiers with normal output  
current of 300A and above have natural  
convection with forced air.



#### NOISE LEVEL

Maximum 65 dBA according D/n 45632



#### INSTRUMENTS

Chargers output voltmeter and Ammeter  
72 x 72mm, 1.5% accuracy 90 deflect  
for MG 36 & 47 cabinet. 96 x 96mm  
1.5% accuracy 90 deflection for MG 62  
& 62D cabinet.



#### AUTO CHARGE CONTROL

Auto charge control for automatic  
switching to high rate after battery  
discharge and back to float charge after  
the battery is fully charged.  
(Standards 8 hours)



**STABLE DC POWER.  
STRONGER OPERATIONS.**



OIL & GAS



CHEMICAL &  
PETROCHEMICAL



POWER  
GENERATION



POWER  
DISTRIBUTION



TELECOMMUNICATION

# TECHNICAL FEATURES OPTIONAL

## STANDARD ALARM PACKAGE



### CHARGER FAIL

Used for sensing failures in the charger by monitoring the voltage and current functions.



### LOW DC VOLTAGE

Used for sensing low voltage.

**Adjustment** : 70 - 150% V nominal  
**Hysteresis** : 2%

**Usual settings:**

- battery low voltage : 1.1V/c NiCd, 1.8V/c Lead Acid



### HIGH DC VOLTAGE

Used for sensing high voltage.

**Adjustment** : 70 - 150% V nominal  
**Hysteresis** : 2%

**Usual settings:**

- battery high voltage : 1.7V/c NiCd, 2.5V/c Lead Acid



### EARTH FAULT

Discriminate sensing of positive and negative earth faults in ungrounded systems. Fault current adjustment set @ 10mA  
**Hysteresis** : 2%



### AC FAIL

Used for sensing low mains voltage.



### INDICATORS

All alarms are indicated by red LED's on the front door.



### GROUP REMOTE ALARM

A group remote alarm relay is included as a standard feature. The relay has a potential free change over contact and is de-energized upon alarm.

240V AC, 5A, 480VA,  
100V DC, 5A, 120W



### LED TEST / RESET

All alarms are latched after being activated. Two push buttons facilities for LED test and reset of alarms.



### LOW ELECTROLYTE LEVEL ALARM

An alarm module in conjunction with a probe installed on a pilot cell in the battery will signal low electrolyte level.

This option is only available for Nickel Cadmium batteries containers.



### AUDIBLE ALARM

For local annunciation of a selected alarm function or as group alarm.



### SELECTIVE REMOTE ALARM

A selective remote alarm system is available as option and can be installed for each alarm for selected alarms only. For contact rating see group remote alarm.



### OVERTEMPERATURE

The alarm indicates excessive high temperature and initiates charger shutdown by inhibiting the control to the rectifier bridge.



### DC FUSE TRIP ALARM

Indication of blown on DC load output fuse.



### LOW VOLTAGE DISCONNECT ALARM

Low voltage disconnect, to disconnect the load from the battery when the voltage level decreases below a preset level. The option includes an output contactor. Manual reset after battery voltage reaches a preset level.



### HIGH VOLTAGE SHUTDOWN ALARM

High voltage shutdown to shutdown the charger when this output voltage exceeds a preset level. The option includes an input circuit breaker with shunt trip.



**ENGINEERED FOR  
CRITICAL POWER.**  
**BUILT FOR RELIABILITY.**



OIL & GAS



CHEMICAL &  
PETROCHEMICAL



POWER  
GENERATION



POWER  
DISTRIBUTION



TELECOMMUNICATION

# TECHNICAL FEATURES OPTIONAL

CUSTOMIZED SOLUTIONS.  
ENHANCED PERFORMANCE.  
MAXIMUM RELIABILITY.

## OTHER FEATURES ON REQUEST



### METERING AND TRANSDUCER

Additional analogue or digital metering is available. The angle of deflecting can be of 240 degrees. Transducers for remote monitoring can also be included.

- Battery voltmeter and ammeter
- Input voltmeter and ammeter
- Load voltmeter and ammeter
- Input power and power factor meter
- 4 to 20mA transducer for remote metering



### NON-STANDARD CABINET

Upon request, the cabinet can be painted with a non-standard color if available. Color codes are Munsell or RAL. The degree of protection (IP rating as according to IEC529 e.g. IP21, IP32, IP43 etc.) can be increased to suit different environment.



### AUTO TRANSFER SWITCH

An automatic transfer switch can be installed at the incoming line when there are two sources of incoming supply. The switch automatically transfers the main incoming supply to the alternate supply when the main supply fails. A selection switch can be included for the selection of either supply as the main supply.



### PARALLEL-LOAD SHARING

Additional blocking diode is recommended at each charger output. Load sharing card to load share several chargers can be connected in parallel.



### LOAD SHEDDING CIRCUIT

Contactors together with timers are used to shed the respective load at different time elapse on battery discharging.



### REVERSE BATTERY POLARITY PROTECTION

The internal components of the equipment are protected with an added protection circuit installed in the equipment. This option is to avoid the damage caused to the equipment when the battery bank and rectifier meet at opposite polarity.



### INTERIOR CABINET LIGHTING

An interior cabinet light is provided with a door interlocking switch. The interior light is only operated when the door is open and switches off automatically when door closes.



### BATTERY TEST

An internal load is built in the charger to perform a discharge on the battery to reconfirm the functionality of the battery. The battery test is carried out with the rectifier providing to the load.



### CIRCUIT BREAKERS

The circuit breakers can be installed at different points along the system to enhanced each application. Shunt tripping, motorized breaker, padlocking, mechanical interlocking, electrical interlocking and other features of the breakers can be included.

- Miniature Circuit Breaker (up to 100A)
- Mould Case Circuit Breakers (up to 1600A)
- Air Circuit Breaker (for higher current)



### BATTERY BOX

Battery breakers or fuses can be located inside a high grade plastic / polycarbonate box or a metal enclosure.



### SLOW RECHARGING OF CAPACITORS

This option is recommended when the equipment is designed with a battery switch or breaker. The filtering capacitors are always present. A step input voltage bank can generate a very high current.



### BATTERY ROOM FAN CONTROL

A voltage free contact signal can be provided to the charger unit to inhibit the Hi-Rate activity upon failure of the battery room fan.



ENGINEERED FOR CRITICAL POWER.  
BUILT FOR RELIABILITY.



OIL & GAS



CHEMICAL & PETROCHEMICAL



POWER GENERATION



POWER DISTRIBUTION



TELECOMMUNICATION

# TECHNICAL FEATURES

## OPTIONAL

ENHANCED FLEXIBILITY.  
GREATER RELIABILITY.



### TELECOM FILTER

Psophometric ripple voltages are measured within a specific bandwidth described under the CCTIT norms which state that for Telecom purposes, the requirements must match the "C" curve. The ripple voltage requirement is 0.1% of the nominal output and 2mV psophometric value.



### INPUT EMI FILTER

An input EMI filter is installed if requirement specify a normalized for conducted Electrical Magnetic Interference (EN50082-2)



### BATTERY CURRENT LIMIT

This option is used to prevent excessive charging current to the connected battery. Whenever the battery current reaches a preset value, the rectifier will be current limited independent of the load current.



### BATTERY TEMPERATURE COMPENSATION

This option is used whenever a battery needs charge compensation with respect to the ambient temperature. The charge voltage decreases automatically when the ambient temperature of the battery increases.



### OTHERS

Please consult our sales personnel for other options.

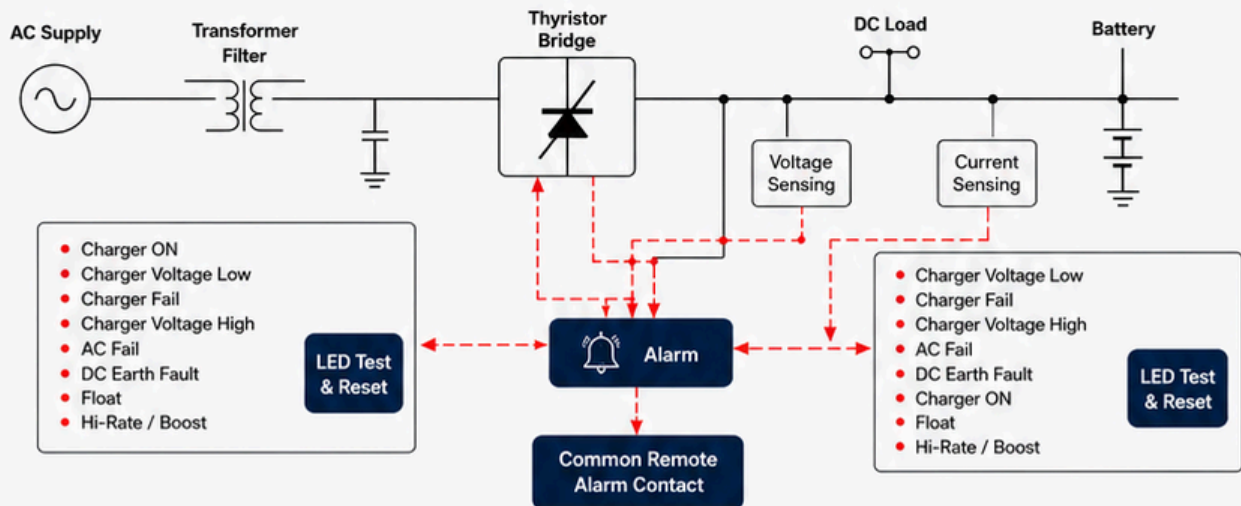

ENGINEERED FOR  
CRITICAL POWER.  
BUILT FOR RELIABILITY.



OIL & GAS



CHEMICAL &  
PETROCHEMICAL



POWER  
GENERATION



POWER  
DISTRIBUTION



TELECOMMUNICATION

# SYSTEM CONFIGURATIONS

## OPTIONAL SOLUTIONS

Engineered Redundancy.  
Enhanced Reliability. Continuous DC Availability.

### 01 DROPPING DIODE DEVICES

Battery-voltage-controlled output regulation using dropping diodes. The system limits load voltage to within  $\pm 10\%$  of the nominal DC output voltage.

A DC voltmeter with a selector switch is provided to measure either the load voltage or battery voltage.

An independent unregulated output for non-critical loads is also available.

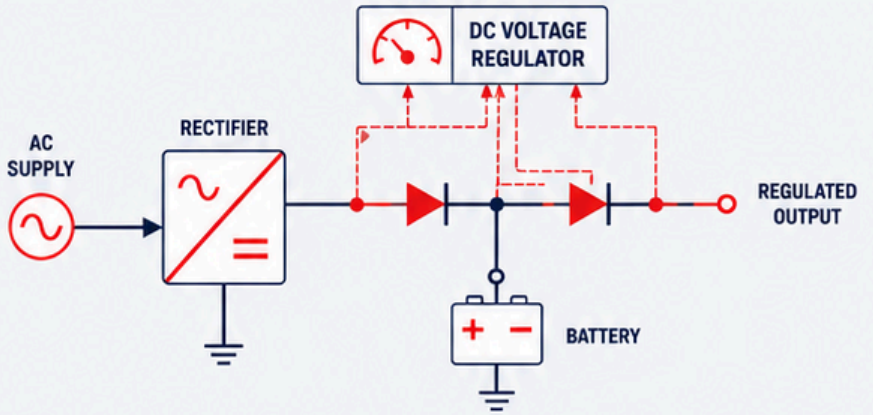

- VOLTAGE REGULATION
- BATTERY / LOAD MONITORING
- NON-CRITICAL LOAD OUTPUT

### 02 LOAD CURRENT SHARING (DUAL DC SYSTEM)

Designed for redundant DC power systems where multiple chargers/rectifiers operate in parallel.

The load-sharing controller automatically balances the output current among all connected chargers/rectifiers, ensuring each unit contributes proportionally to its rated capacity.

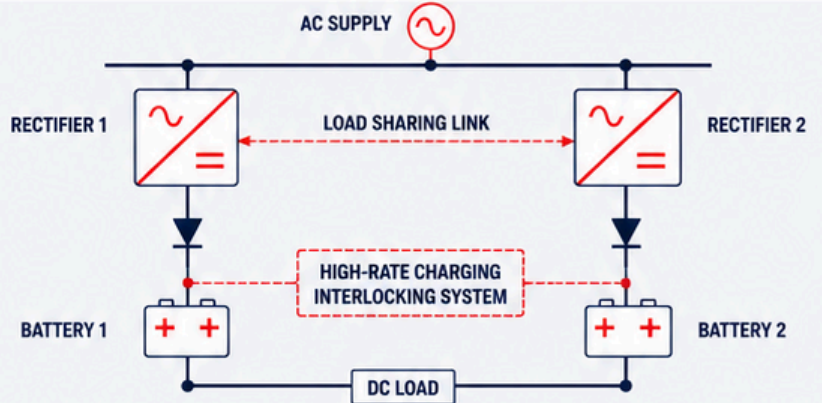

- N+1 REDUNDANCY
- EQUAL LOAD DISTRIBUTION
- IMPROVED AVAILABILITY

### 03 END CELL SWITCHING (HOT STANDBY SYSTEM)

Provides output voltage regulation using a divided battery arrangement.

Additional battery cells are automatically switched in when the load voltage drops below the lower threshold and switched out when the upper threshold is restored.

A voltmeter selector switch for Battery / Load voltage monitoring is included as part of this configuration.

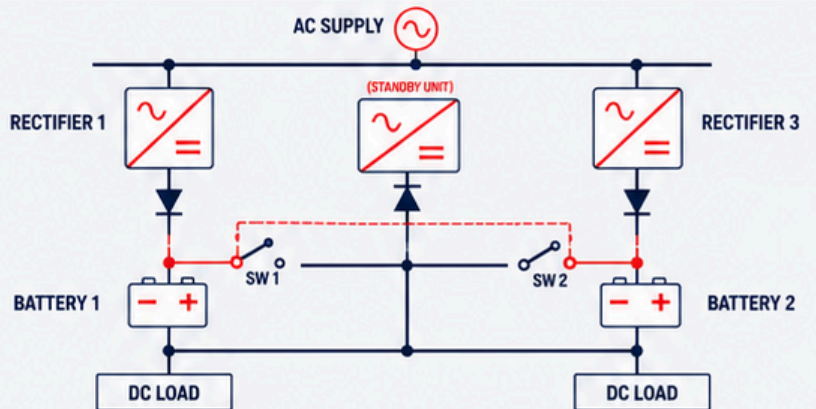

- UNINTERRUPTED TRANSFER
- EXTENDED BATTERY UTILIZATION
- AUTOMATIC VOLTAGE OPTIMIZATION



ENGINEERED FOR  
CRITICAL POWER.  
BUILT FOR RELIABILITY.



OIL & GAS



CHEMICAL &  
PETROCHEMICAL



POWER  
GENERATION



POWER  
DISTRIBUTION



TELECOMMUNICATION

# SINGLE-PHASE BATTERY CHARGER FD1 SERIES

Reliable charging solutions.  
Engineered for continuous performance.



## FINISH

Metal is electro galvanised, chemical rust inhibitor, epoxy powder coating.



## COLOUR

Similar RAL 7032 (light grey)

- The DA Series cabinets are made of 1.5mm thick electro galvanised sheet steel.
- The DB36 and DB47 Series cabinets are made of 1.5mm and 2mm thick electro galvanised sheet steel for the panel and frame respectively.
- The DB60 Series cabinets are made of 2mm and 3mm thick electro galvanised sheet steel for the panel and frame respectively.



## DEGREE OF PROTECTION

IP20 according to IEC144 (other protection class on request)

## CABINET DIMENSIONS

MODEL	HEIGHT	WIDTH	DEPTH
DA14	460	400	270
DA18	610	430	330
DA21	790	500	380
DB36	1230	670	490
DB47	1630	670	490
DB62	1900	840	800
DB62D	1900	1640	800

Dimensions in millimetres

## TECHNICAL DATA

12 V DC				
MODEL	CABINET	WEIGHT NOM. kg	NOM. VOLT. V DC	NOM. CUR. A DC
FD1-12-25	DB36	60	12	25
FD1-12-35	DB36	70	12	35
FD1-12-50	DB36	80	12	50
FD1-12-75	DB36	100	12	75
FD1-12-100	DB36	120	12	100
FD1-12-125	DB36	135	12	125
FD1-12-150	DB36	150	12	150
FD1-12-175	DB36	175	12	175
FD1-12-200	DB36	190	12	200
FD1-12-250	DB36	236	12	250

24 V DC				
MODEL	CABINET	WEIGHT NOM. kg	NOM. VOLT. V DC	NOM. CUR. A DC
FD1-24-25	DB36	80	24	25
FD1-24-35	DB36	100	24	35
FD1-24-50	DB36	125	24	50
FD1-24-75	DB36	185	24	75
FD1-24-100	DB36	190	24	100
FD1-24-125	DB36	200	24	125
FD1-24-150	DB47	210	24	150
FD1-24-175	DB47	230	24	175
FD1-24-200	DB47	250	24	200
FD1-24-250	DB62	385	24	250
FD1-24-300	DB62	410	24	300
FD1-24-400	DB62	525	24	400
FD1-24-500	DB62D	650	24	500

48 V DC				
MODEL	CABINET	WEIGHT NOM. kg	NOM. VOLT. V DC	NOM. CUR. A DC
FD1-48-25	DB36	130	48	25
FD1-48-35	DB36	130	48	35
FD1-48-50	DB36	150	48	50
FD1-48-75	DB62	226	48	75
FD1-48-100	DB62	246	48	100
FD1-48-125	DB62	300	48	125
FD1-48-150	DB62	360	48	150
FD1-48-175	DB62	410	48	175
FD1-48-200	DB62	420	48	200
FD1-48-250	DB62	515	48	250
FD1-48-300	DB62	555	48	300
FD1-48-400	DB62	610	48	400
FD1-48-500	DB62D	720	48	500

110 V DC				
MODEL	CABINET	WEIGHT NOM. kg	NOM. VOLT. V DC	NOM. CUR. A DC
FD1-110-25	DB36	150	110	25
FD1-110-35	DB36	170	110	35
FD1-110-50	DB47	270	110	50
FD1-110-75	DB47	400	110	75
FD1-110-100	DB62	425	110	100
FD1-110-125	DB62	455	110	125
FD1-110-150	DB62	490	110	150
FD1-110-175	DB62	520	110	175
FD1-110-200	DB62	630	110	200
FD1-110-250	DB62D	720	110	250
FD1-110-300	DB62D	920	110	300
FD1-110-400	DB62D	1090	110	400
FD1-110-500	DB62D	1200	110	600

220 V DC				
MODEL	CABINET	WEIGHT NOM. kg	NOM. VOLT. V DC	NOM. CUR. A DC
FD1-220-25	DB47	190	220	25
FD1-220-35	DB47	190	220	35
FD1-220-50	DB62	390	220	50
FD1-220-75	DB62	490	220	75
FD1-220-100	DB62	530	220	100
FD1-220-125	DB62	570	220	125
FD1-220-150	DB62D	750	220	150
FD1-220-175	DB62D	810	220	175
FD1-220-200	DB62D	860	220	200
FD1-220-250	DB62D	1000	220	250
FD1-220-300	DB62D	1350	220	300



**ENGINEERED FOR  
CRITICAL POWER.  
BUILT FOR RELIABILITY.**



OIL & GAS



CHEMICAL &  
PETROCHEMICAL



POWER  
GENERATION



POWER  
DISTRIBUTION



TELECOMMUNICATION

# THREE-PHASE BATTERY CHARGER FD3 SERIES

Reliable charging solutions.  
Engineered for continuous performance.



## FINISH

Metal is electro galvanised, chemical rust inhibitor, epoxy powder coating.



## COLOUR

Similar RAL 7032 (light grey)

- The DA Series cabinets are made of 1.5mm thick electro galvanised sheet steel.
- The DB36 and DB47 Series cabinets are made of 1.5mm and 2mm thick electro galvanised sheet steel for the panel and frame respectively.
- The DB60 Series cabinets are made of 2mm and 3mm thick electro galvanised sheet steel for the panel and frame respectively.



## DEGREE OF PROTECTION

IP20 according to IEC144 (other protection class on request)

## CABINET DIMENSIONS

MODEL	HEIGHT	WIDTH	DEPTH
DA14	460	400	270
DA18	610	430	330
DA21	790	500	380
DB36	1230	670	490
DB47	1630	670	490
DB62	1900	840	800
DB62D	1900	1640	800

Dimensions in millimeters

## TECHNICAL DATA

12 V DC				
MODEL	CABINET	WEIGHT NOM. kg	NOM. VOLT. V DC	NOM. CUR. A DC
FD3-12-25	DB36	60	12	25
FD3-12-35	DB36	70	12	35
FD3-12-50	DB36	80	12	50
FD3-12-75	DB36	100	12	75
FD3-12-100	DB36	120	12	100
FD3-12-125	DB36	135	12	125
FD3-12-150	DB36	150	12	150
FD3-12-175	DB36	175	12	175
FD3-12-200	DB36	190	12	200
FD3-12-250	DB36	220	12	250

24 V DC				
MODEL	CABINET	WEIGHT NOM. kg	NOM. VOLT. V DC	NOM. CUR. A DC
FD3-24-25	DB36	80	24	25
FD3-24-35	DB36	100	24	35
FD3-24-50	DB36	120	24	50
FD3-24-75	DB36	185	24	75
FD3-24-100	DB36	190	24	100
FD3-24-125	DB36	200	24	125
FD3-24-150	DB36	210	24	150
FD3-24-175	DB47	230	24	175
FD3-24-200	DB47	250	24	200
FD3-24-250	DB62	385	24	250
FD3-24-300	DB62	410	24	300
FD3-24-400	DB62	525	24	400
FD3-24-500	DB62D	650	24	500

48 V DC				
MODEL	CABINET	WEIGHT NOM. kg	NOM. VOLT. V DC	NOM. CUR. A DC
FD3-48-25	DB36	125	48	25
FD3-48-35	DB36	130	48	35
FD3-48-50	DB36	150	48	50
FD3-48-75	DB36	220	48	75
FD3-48-100	DB62	245	48	100
FD3-48-125	DB62	300	48	125
FD3-48-150	DB62	400	48	150
FD3-48-175	DB62	410	48	175
FD3-48-200	DB62	420	48	200
FD3-48-250	DB62	515	48	250
FD3-48-300	DB62	555	48	300
FD3-48-400	DB62	610	48	400
FD3-48-500	DB62D	720	48	500

110 V DC				
MODEL	CABINET	WEIGHT NOM. kg	NOM. VOLT. V DC	NOM. CUR. A DC
FD3-110-25	DB36	150	110	25
FD3-110-35	DB36	170	110	35
FD3-110-50	DB47	270	110	50
FD3-110-75	DB47	400	110	75
FD3-110-100	DB62	425	110	100
FD3-110-125	DB62	455	110	125
FD3-110-150	DB62	190	110	150
FD3-110-175	DB62	520	110	175
FD3-110-200	DB62	630	110	200
FD3-110-250	DB62D	720	110	250
FD3-110-300	DB62D	920	110	300
FD3-110-400	DB62D	1090	110	400
FD3-110-500	DB62D	1200	110	600

220 V DC				
MODEL	CABINET	WEIGHT NOM. kg	NOM. VOLT. V DC	NOM. CUR. A DC
FD3-220-25	DB47	190	220	25
FD3-220-35	DB47	190	220	35
FD3-220-50	DB62	390	220	50
FD3-220-75	DB62	490	220	75
FD3-220-100	DB62	530	220	100
FD3-220-125	DB62	570	220	125
FD3-220-150	DB62D	750	220	150
FD3-220-175	DB62D	810	220	175
FD3-220-200	DB62D	860	220	200
FD3-220-250	DB62D	1000	220	250
FD3-220-300	DB62D	1350	220	300



ENGINEERED FOR  
CRITICAL POWER.  
BUILT FOR RELIABILITY.



OIL & GAS



CHEMICAL &  
PETROCHEMICAL



POWER  
GENERATION



POWER  
DISTRIBUTION



TELECOMMUNICATION

# DELIVERING NON-STOP POWER THROUGH FUKUDA



SINCE  
**1998**



FUKUDA DC UPS – **FD1 & FD3 SERIES**  
PROVEN AND INSTALLED ON  
**ONSHORE PLANTS / OFFSHORE PLATFORMS**  
SINCE 1998.



### UNINTERRUPTED RELIABILITY

Engineered to deliver continuous DC power for critical systems.



### RUGGED & DURABLE

Built for demanding environments with robust, industrial-grade components.



### PROVEN PERFORMANCE

Trusted by industries worldwide with thousands of successful installations.



### EASY MAINTENANCE

Smart design for quick installation, easy access and simplified maintenance.



### SAFE & COMPLIANT

Designed to meet international standards for safety, EMC and performance.

ENGINEERED  
FOR CRITICAL POWER.  
BUILT FOR RELIABILITY.



OIL & GAS



CHEMICAL &  
PETROCHEMICAL



POWER  
GENERATION



POWER  
DISTRIBUTION



TELECOMMUNICATION